

G600 Treadmill LK6000**Detailed Technical Specifications**

Running area (LxW)	55 x 160 cm
Motor	4.0 HP AC
Tilt	0 - 15 %
Speed	0.8-22 km/h
Maximum user weight	180 kg
Heart rate monitoring	pulse sensors at handlebar and Polar telemetric heart rate monitoring
Programs	28 exercise profiles, manual program, customizable user program, Woman Fitness test, Man Fitness Test and HRC program (Heart Constant frequency program)
Rate	
On-screen information:	Speed, Distance, Time, Calories, Pulse rate, Inclination, exercise profile
Emergency Stop	Emergency Stop Button at front Toolbar and automatic stop system MOB (string)
Accessories	Double holder for bottles, keys, etc., jack connection for mp3.

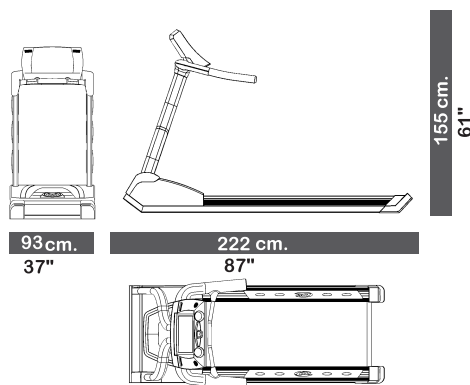

G600 Treadmill LK6000

- **Quiet, reliable 4.0 HP AC motor** Produces speeds of between 0.8 and 22 km/h with maximum silence. It guarantees power and durability with minimum consumption, thanks to a more efficient use of energy, which leads to a lower consumption for the same performance.
- **Smart impact absorption system**, for more fluid running, as it controls and absorbs the force of each step on the board, helping to maintain a constant speed during exercise.
- **Progressive damping elastomers**. Its advanced technology elastomers gently absorb the first impact of the foot and harden the damping as users bend and lift their foot from the platform. This ensures correct damping that prevents joint and muscle pain in the knees and feet.
- **Innovative design with an attractive curved profile S-shaped monitor** with a carefully studied slope for an enhanced view of the display and a more ergonomic posture.
- **Connection for mp3 and built-in speakers**, which let the user listen to their own music while exercising.
- **XXL running surface**, for a safe and comfortable workout.
- **Central electric single shaft inclination system** that allows a maximum gradient of 15%.
- **Powerful double-speed fan**, for a more rewarding exercise experience.
- **Band with tough, flexible, slip resistant, absorbent PVC surface**. This surface is highly resistant to abrasion, mechanical strength and shock proof and it is also recyclable.
- **Magnetic speed sensor**, used to detect and prevent potential problems.
- **Wheels**, for easy transportation.
- **Monitor: DOT MATRIX screen with top LED window** that graphically displays the progress of the exercise. The bottom alphanumeric display gives the user instructions before and during the exercise. The 4 LED windows at the very bottom simultaneously show information for Speed, Time/Distance, Calories/Tilt and Pulse rate.
- **Monitored heart rate**: measured either by contact with the handlebar or via telemetry (Integrated POLAR compatible receiver).



G600 Treadmill LK6000

- **Easy Toolbar** for quick, instant access built into the front handrail, this includes pulse rate contact sensors, one-finger speed and tilt buttons and emergency stop.
- **Programs:** Manual, 7 preset profiles with 4 different levels of difficulty and intensity each, user programmable profile, Man Fitness Test, Woman Fitness Test, and Heart Rate Constant program.
 - Heart Rate Constant program (HRC). Allows cardiovascular zones to be targetted during exercise. Automatically controls workout intensity to maintain effort at selected pulse limits.
 - Man/Woman Fitness Test. Allows to evaluate the shape and physical condition of the user.
 - Customizable user program. Allows to customize and configure your own training profile.

