

## R250: Stepper SK2500

- Casing: Hard-wearing ABS plastic and easy to clean.
- Desing: Professional stair stepping machine which has been designed for hard wear and continual use in gyms.
- Electromagnetic brake system with generator. Maximum reliability and precision. No need for electric mains except for the monitor.
- Programs Manual, 8 preset profiles with 4 intensity levels each, User Program, Fitness Test for Men and Women, HRC and Distance Program.
- On-screen information: time, distance, speed, inclination, pulse, calories and program profile.
- Frame: Aluminium and sturdy oval section steel tube ST52. Bearings Heavy duty SKF bearings. Top quality finishes on all components.
- Genesis III: New generation of self-powered technology.
- Multyposition handlebar: Allows the user to adopt the most natural position during exercise.
- Recovery system: Chains and pulleys.
- Connection for mp3 and built-in speakers, which let the user listen to their own music while exercising.
- Stepper with independent system.
- Helpful wheels for transportation.
- Variable geometry low-impact steps.
- Pulse measurement both by contact pulse and telemetric pulse (chest band optional)
- Specifications:

Length: 122cm / 48"

Height: 172 cm / 68"

Width: 77cm / 30"

Weight: 118Kg / 260 lbs.

Maximum user weight: 190Kg / 419 lbs.

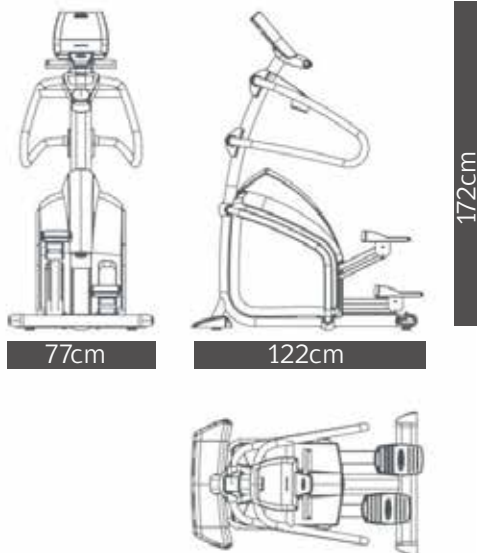

## R250: Stepper SK2500

● Two monitor option:

1 **Smart Focus Monitor TFT capacitive Touch Screen of 16" HD**, besides of showing the evolution and training information (Speed, Time / Distance (km) Calories / Incline, Pulsation in watts, resistance, pulse, etc.), allows full connectivity to social networks, internet, television and applications thanks to the FitFeel interface that provides the fastest touchscreen technology of the market. With Smart Focus you can also customize the monitor, interact with users and customize workouts thanks to its Log in system for each user where they can save all the information of their workouts.

- USB port.
- Smartphones and iPods compatibility.
- Bluetooth Connectivity.
- CSAFE port.

2 **LED Monitor: DOT MATRIX screen with top LED window** that graphically displays the progress of the exercise. The bottom alphanumeric display gives the user instructions before and during the exercise. The 4 LED windows at the very bottom simultaneously show information for Speed, Time/Distance, Calories/Tilt and Pulse rate.

